



## Milano

2011

Scrivania direzionale con struttura e cassetti in frassino naturale, tinto tabacco o laccato nero poro aperto. Piano in cristallo trasparente o extralight 15mm. Disponibile anche piano in cristallo "grigio Italia" 12mm temperato. Sottomano in pelle scamosciata nei colori del campionario.

Cm (L x W x H)

182 x 90 x 75

232 x 90 x 75

Sottomano / Writing pad

50 x 57

100 x 57

Inches (L x W x H)

71<sup>3</sup>/<sub>4</sub> x 35<sup>1</sup>/<sub>2</sub> x 29<sup>3</sup>/<sub>4</sub>

91<sup>1</sup>/<sub>2</sub> x 35<sup>1</sup>/<sub>2</sub> x 29<sup>3</sup>/<sub>4</sub>

Sottomano / Writing pad

19<sup>3</sup>/<sub>4</sub> x 22<sup>1</sup>/<sub>2</sub>

39<sup>1</sup>/<sub>2</sub> x 22<sup>1</sup>/<sub>2</sub>

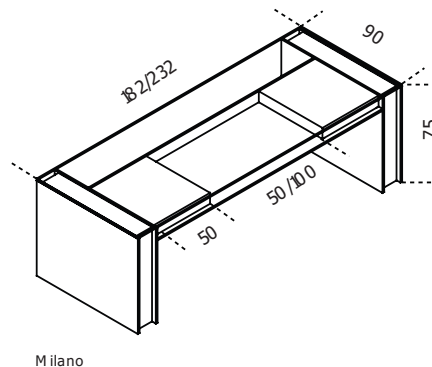
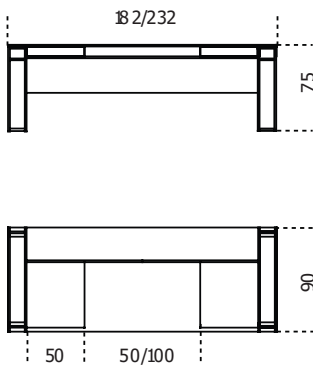



# Finiture

## Cristallo

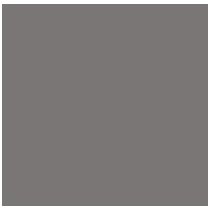

"Grigio Italia"



Extralight

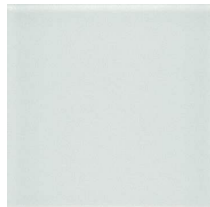

Trasparente

## Legno



Frassino laccato  
nero poro aperto



Frassino naturale



Frassino tinto  
tabacco

## Pelle Cat.L1

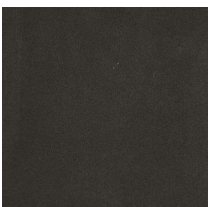

Suede grey 020



Suede grey 058



Suede grey 074



Suede sand 006



Suede sand 012